

modulo  
            
WAY

I M A G I N E  
B E I N G A B L E  
T O D E S I G N  
T H E P L A C E  
O F B E A U T Y  
Y O U ' V E A L W A Y S  
W A N T E D .



Of being able to translate your personal idea of **harmony, elegance and practicality** into **decor**, accessorising it with everything you need in order to transform it into the most **efficient and comfortable work environment** for you and **to adjust the details** so that they become the concrete extension of **how you approach your daily life**. If your **ideal furniture** has taken shape, it's time to design it and put it into practice with Oway.

# M O D U L O

---

**Modulo is Oway's world of circular furniture**, developed in our 0 km wood workshop, **Artigiano**, a manufacturing laboratory where customised, ecological and refined accessories and solutions are created for places belonging to the Oway universe. A unique and innovative project, based on the pillars of **refinement, craftsmanship and attention to detail**.

An innovative **modular tailor-made line** developed starting from the principles of **Oway Agricosmetics**, with its range of **differentiating values**, from the principles of **circular design** to the advantages of **eco-design**, from **craftsmanship** to **unique solutions**, through total **characterisation** and the choice of **100% plastic-free sustainable materials**.

Inspired by the concept of **modularity**, the rich **offer of furnishing combinations** is based on a **flexible design approach**, capable of mixing **aesthetics, functionality and uniqueness** and of delivering these into the hands of beauty professionals, ensuring the realm of their treatments is an **original environment, far from seriality and homologation**. In accordance with the **Organic way of life**, salons, beauty centres and spas are thus transformed into oases of **authentic well-being**, where **relaxing colours** and **natural materials** concretely improve the quality of the experience of those who work there and of those who benefit from the treatments.

---



## / AGRICOSMETICS IN THE SALON /

Each set-up created with Modulo corresponds to a specific furnishing situation, which must reflect the identity of your business but also **characterise it in a distinctive way**. In addition to the **green approach** and to the guarantee given by **certifications on materials, products and processes**, there is a value of Oway Agricosmetics that our furniture collection could not fail to have, and it is precisely the starting point of Agricosmetics itself: **cultivation**. Compared with traditional furniture, we have added an element of innovation linked to **indoor gardening**, a small **green corner**, created in the structure of the chest and illuminated from above, completed by a space for gardening equipment and **designed to encourage constant care for the plants**. Green habits are the ingredient that makes our circular system practicable at every level of everyday life, in all choices and in every aspect of the Organic Way lifestyle. 

---



## / ITEMS AND COMBINATIONS /

The Modulo offer **adapts to various locations and different sizes**, responding flexibly both to **furnishing requirements and to those of daily routines**. You can create **625 different set-ups**, starting from the choice of **armchairs, hair wash units, mirrors, back wash cabinets, service furniture, chests and trolleys** available in five **colours** and as many finishes for **handles, textures and coverings**. 

---

## / MATERIALS /

The recurring element of all the furnishing elements is **wood**, the material capable of defying time and of projecting us into the relaxing atmospheres of nature. All furniture is made of **solid FSC (Forest Stewardship Council)** or **recycled wood**. Solid wood, precious and resistant, comes from an ethical and responsible management of forests, while recycled derivatives come from previous woodworking. In order to guarantee a **refined and characterising design** and to obtain **maximum functionality**, Modulo also produces, **on request, unique pieces without coated or veneered semi-finished products, nor ennobled** by melamine resins and **finishes them with painting and lacquering** according to the dictates of ancient manufacturing traditions. 

---



## / PAINTS AND COATINGS /

Covering a piece of furniture corresponds to "giving it lustre". It involves the conscious choice of the **most suitable, least harmful and most ecological films**, both in the immediate and long term.

To perfect every single article, we explored the variegated world of lacquers and varnishes, with the sole objective of safeguarding the leading role of the wood grain.

Among these, **bio water paint** turned out to be the elegant ally most faithful to our circular values: a formula studied for wood which **respects the planet, reduces carbon dioxide emissions** and **preserves the health of people**, maintaining the same results as the solvent alternatives. Fully consistent with our supply chain standards, in this case too, **sustainability involves the entire production chain**, from recycled raw materials to processes with reduced environmental impact.

Aware of the wealth of km 0 resources of our territory, we went in search of something that would make the difference. We came across **Emilia Romagna's fully vitrified stoneware**, today at the base of all the coverings of the modular project. 

---



# Artigiano

WAY



At Organic Way we implement choices in favour of the environment which are touched and **built** – first hand. To close the circle of **concretely sustainable actions** and to give our appearance an **elegant, distinctive and highly tactile line**, in 2017 we decided to become **craftsmen** and **wood designers** in addition to agricultural and cosmetic producers.

**ARTIGIANO** is the **Organic Way** laboratory where certified wood furniture and communication materials are created locally and dedicated to places of beauty all over the world. It is the natural outlet for a project that starts from the product and ends at a **lifestyle**, revealing itself with green chemistry and green habits formula choices and with the universe of **interior design**.



## / OBJECTIVE: CIRCULAR ELEGANCE /

Artigiano was established to create unique pieces of furniture, but also particular types of **packaging and exhibition and communication material** with a **multifunctional, reusable, sustainable and elegant design**. All these artefacts are intended for all those corporate areas which mirror the Organic way of life, the places of beauty and the shops: the laboratories where our beliefs become real. The workplace becomes a positive and virtuous environment that narrates the unique values of the brand and of those who choose it, thanks also to these **ecological, durable and quality furnishing accessories and work tools**.

## / THE CONSCIOUS (AND FLEXIBLE) ORIGINALITY OF THE OW SPACES /

At Artigiano, furniture and design supports are designed and created piece by piece in **FSC certified wood**, making the **visual impact** in the salon somewhat different thanks to the naturalness of the components, to the eye-relaxing colours, and to textures which are pleasant to the touch. No piece is the same as another: **seriality has been eliminated**, everything which comes to life inside Artigiano is a one-of-a-kind item, designed **to enhance the identity and originality of your centre**. Studied and designed in the Oway in-house creative department, all the Artigiano products and its **MODULO furniture line** are created in our **zero-mile wood workshop** and there they prepare to enter the places of beauty and daily life, providing sustainable and totally customisable **alternatives to traditional objects and furnishings**. —



## / THE ADVANTAGES OF CIRCULAR DESIGN /

In perfect line with the driving objectives of the entire Oway experience, Artigiano was established **to preserve the enormous capital offered to us by nature**, reducing waste and moving towards increasingly concrete sustainability. The concept of Circular Design is fundamental in every creative act of ours and this is why our eco-design does not stop at furniture: for **OWN WAY**, our Eau de Parfum, we have designed minimal, eco-friendly and durable boxes, created and manufactured right in our zero-mile wood workshop. Starting from a **material obtained from the recovery of wood, 100% recycled**, we have created various types of packaging which can be reused as containers, prolonging their life and usefulness. The woods used in our wood workshop - and in in the **MODULO** furniture line - have achieved **FSC certification**, the international organisation which promotes the responsible management of forests and plantations, defining standards of good and sustainable forest management. —

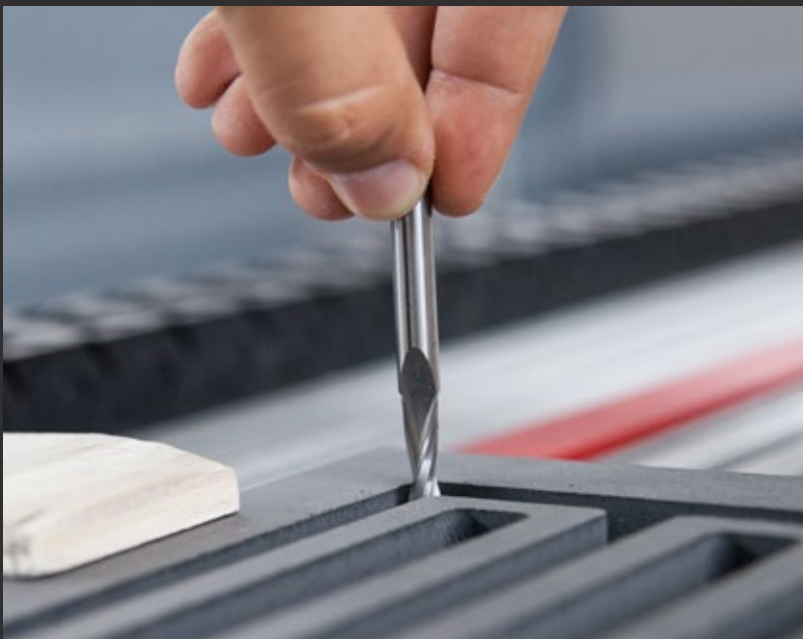

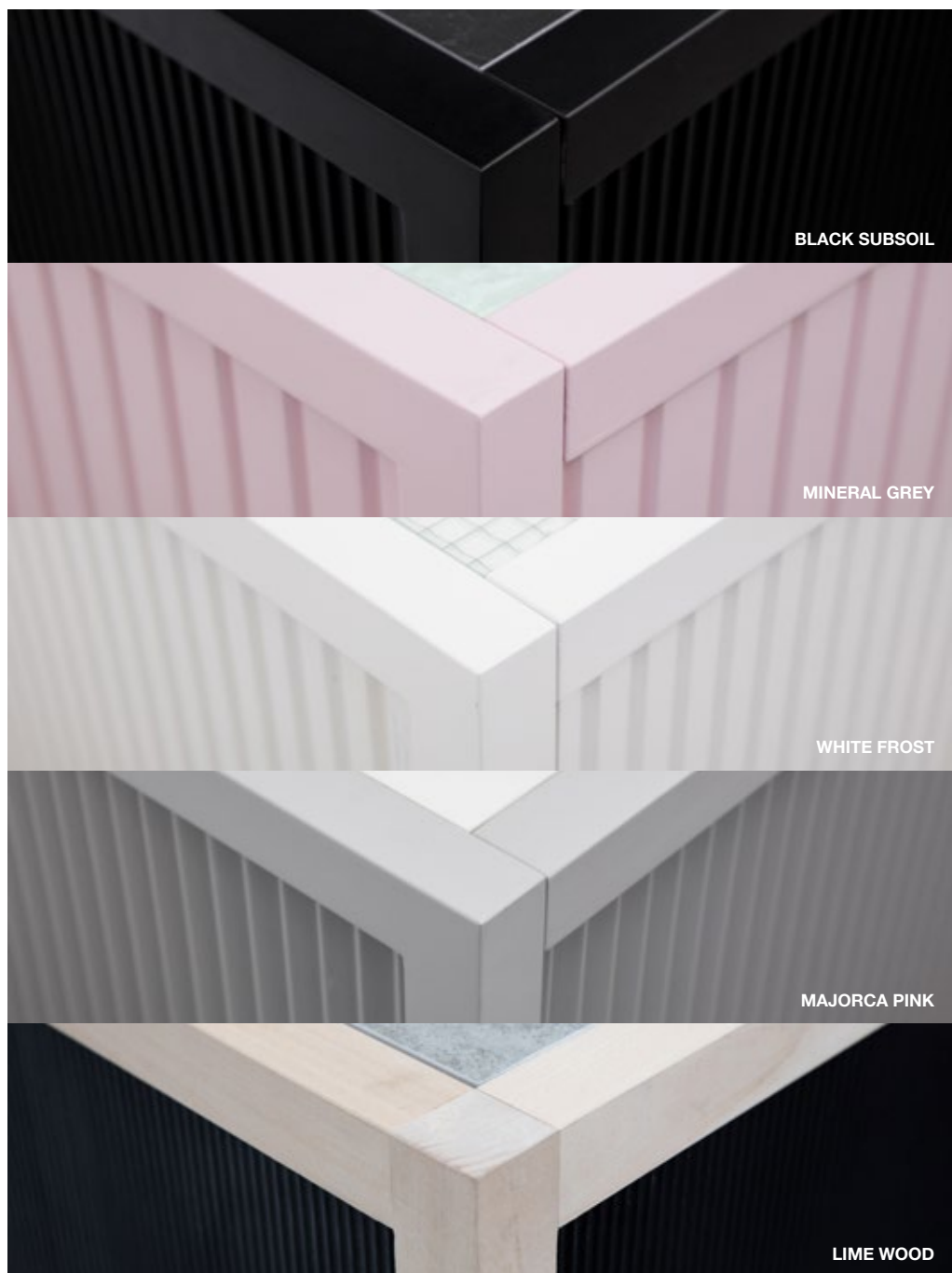

## / COLOURS /

Some environments are already strongly characterised, while others resemble an empty canvas to be painted from scratch. Many colours can be provided for the present of a new beginning and for the future of stories with experience: with Modulo you can customise all the components of your salon, right down to the smallest detail, and **choose the colour/s you prefer for furnishings, finishes and accessories**, building a **warm, refined, luminous, deep or relaxing environment**, according to your needs.



**ORGANIZING STORAGE  
CABINET / SHELVES - p.39**  
Black Subsoil / Round texture /  
Lunar Surface / Gold Knob





**CHILLING WASH UNIT - p.53**  
Black Subsoil / Round texture /  
Deep Cosmos

**MIXING BACK WASH CABINET / LOW - p.40**  
Black Subsoil / Round texture / Lunar Surface / Gold Knob





**BLOOMING DESK - p.43**  
Black Subsoil / Round texture /  
Lunar Surface / Gold Knob

**GROWING TERRACOTTA - p.54**  
Rose Terracotta

**SEPARATING WINDOW - p.49**

Black Subsoil





**CHILLING WASH UNIT - p.53**  
Black Subsoil / Round texture / Deep Cosmos



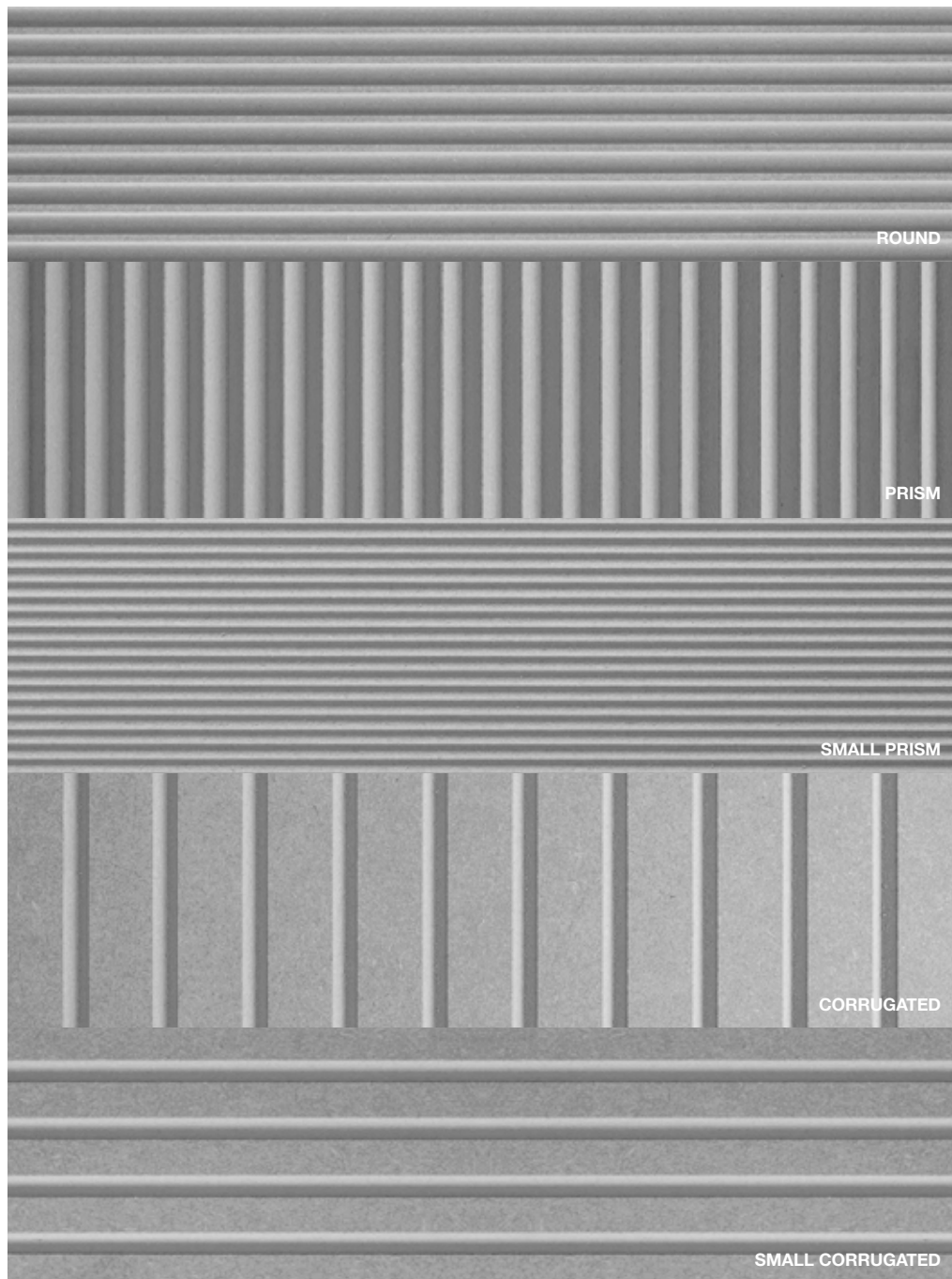

## / TEXTURES /

The Modulo project focuses on **customisation, craftsmanship, sustainable design and sensuousness**. The use of various types of texture and materials is a **precise environmentally friendly choice** and at the same time it is a **tactile experience**, which gives us **a feeling of authentic and refined naturalness**. Textures and surfaces which are pleasant to see and touch provide character and ensure internal environments are more personal and welcoming, in line with the image we wish to portray.

**ORGANIZING STORAGE**  
**CABINET / STORAGE - p.39**

Majorca Pink / Corrugated /  
Pink Clay / White Handle





**BLOOMING DESK - p.43**  
Majorca Pink / Corrugated / Pink Clay /  
White Handle





**CRAFTING TROLLEY - p.45**  
Majorca Pink / Corrugated / Pink Clay /  
White Handle

**ORGANIZING STORAGE  
CABINET / STORAGE - p.39**  
Majorca Pink / Corrugated /  
Pink Clay / White Handle

**GROWING TERRACOTTA / XXL - p.54**  
Rose Terracotta







**ORGANIZING STORAGE  
CABINET / SHELVES - p.39**

Majorca Pink / Corrugated /  
Glass Net / White Handle

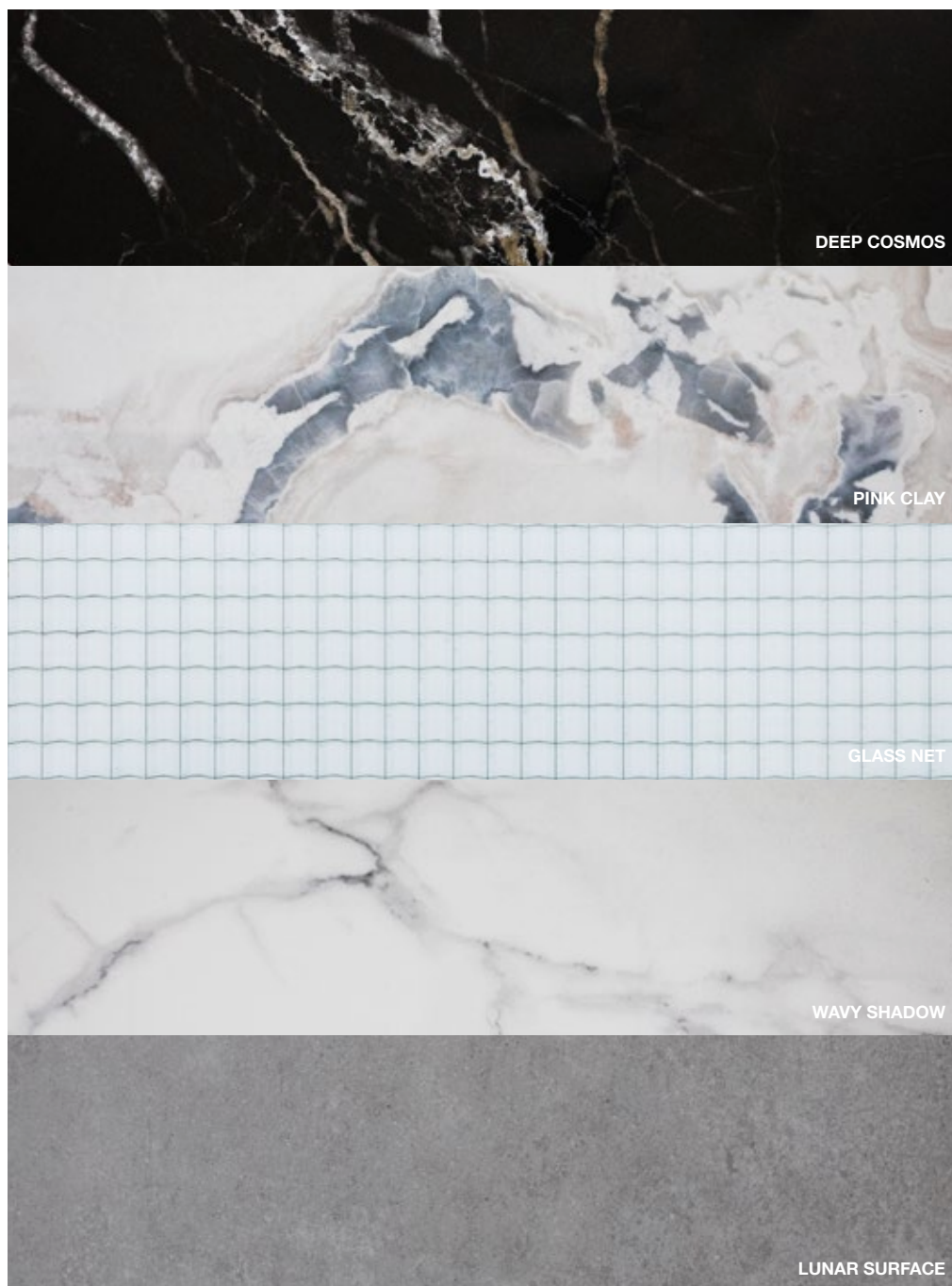

## / WORK COUNTERS /

Bright, resistant, precious. Choosing ceramic means drawing on the advantages and wisdom of **an ancient workmanship**, but also looking for the **compactness** and **water resistance** of a material that is extremely difficult to scratch. One of the main types of ceramics is **stoneware**, which retains the power of a marbled effect whilst **avoiding the use of emissions equal to that of extracting marble** from a quarry, which is very onerous in terms of environmental impact. The **porcelain stoneware from Emilia-Romagna** chosen for the Modulo furnishings benefits from **the added value of being local**, in terms of value and geographical proximity, and at the same time takes shape from raw materials recovered from processing waste. The **Leed Compliant certification** places it among the most ecological and sustainable works produced with the use of photovoltaics, which significantly reduces waste and energy losses.

**CRAFTING UNIT - p.46**  
White Frost / Glass Net



**DE-STRESSING  
ARMCHAIR - p.50**  
Black Subsoil





**CRAFTING UNIT - p.46**  
White Frost / Glass Net

**DE-STRESSING ARMCHAIR - p.50**  
Black Subsoil



**ORGANIZING STORAGE CABINET / LOW - p.39**  
White Frost / Small Corrugated / Glass Net / Metal Knob

**CRAFTING TROLLEY - p.45**  
White Frost / Small Corrugated /  
Glass Net / Metal Knob





**ORGANIZING STORAGE CABINET / STORAGE - p.39**

White Frost / Small Corrugated / Glass Net / Metal Knob



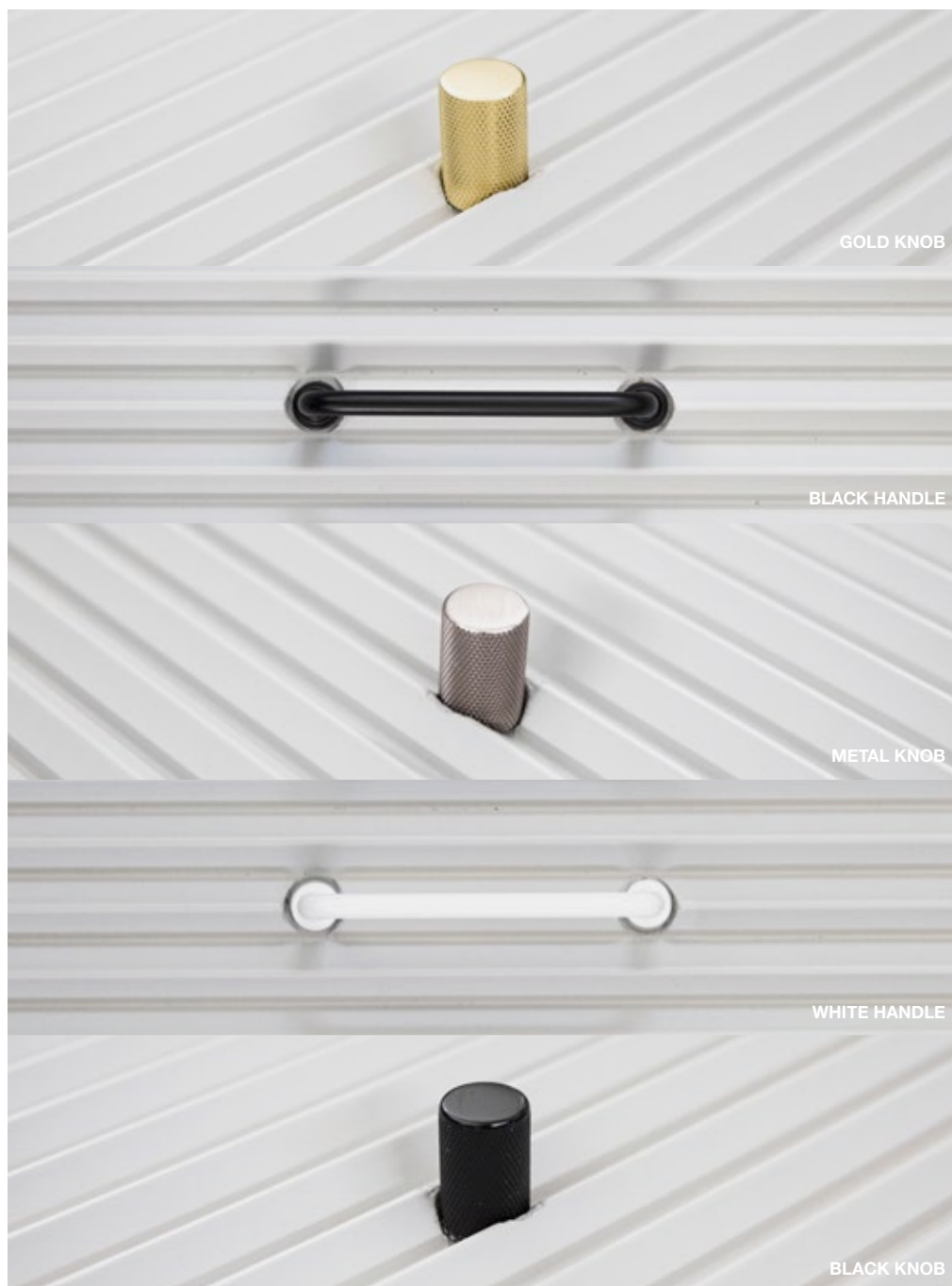

## / HANDLES /

Often underrated, handles and knobs are that **touch of design** which finishes off a furnishing line. In order to help you achieve **the right mix between the functional and the decorative objectives** of your beauty salon, Modulo offers you the possibility of choosing between different types of handles, colours and finishes, relying on the exclusive selection of 100% plastic-free materials and on a **minimal, elegant and essential design**.





**MIXING BACK WASH  
CABINET / STORAGE - p.40**  
Mineral Grey / Prism / Wavy Shadow /  
Black Knob

**GROWING**  
**TERRACOTTA / M - p.54**  
Rose Terracotta





**CHILLING WASH UNIT - p.53**  
Mineral Grey / Prism / Wavy Shadow





**MIXING BACK WASH CABINET - p.40**  
Mineral Grey / Prism / Way Shadow /  
Black Knob





**CRAFTING TROLLEY - p.45**  
Mineral Grey / Prism / Wavy Shadow /  
Black Knob



## / CERTIFICATIONS /

Creating products according to a **circular design** principle means, first and foremost, **developing and disseminating a new sustainable production model**. A rather concrete choice that aims to **enhance the value of resources and of energy**, closely integrating the concepts of an **eco-effective, essential and functional** architecture. To make this furnishing idea a reality, it is not only necessary to **adhere to the principles that characterise the circular economy** model, but also to **actively pursue them**.

The **wood** from which the furnishings and the accessories of the Modulo line are made **are FSC certified** (acronym for the Forest Stewardship Council), certification issued by the association with the same name, which actively promotes **responsible forest management**. Adhering to this standard means reaping the fruits of a deep commitment to respecting our environment and its forests. In order to **combat deforestation**, we also decided **not to use exotic wood** in our production. Having chosen the raw materials, we complete the circular design with a precise idea of the coatings and finishes that will be used. Modulo uses **coatings produced thanks to the recovery of waste materials and starting from renewable energies**, avoiding CO2 emissions during the extraction activity. These coatings are **certified by LEED COMPLIANT** (Leadership in Energy and Environmental Design), a brand synonymous with integrated and truly sustainable design.

**ORGANIZING STORAGE**  
**CABINET / SHELVES - p.39**

Lime Wood / Small Prism / Glass Net / Black Handle







**CRAFTING UNIT - p.46**  
Lime Wood / Glass Net

**DE-STRESSING ARMCHAIR - p.50**  
Black Subsoil





**ORGANIZING STORAGE CABINET / STORAGE - p.39**  
Lime Wood / Small Prism / Glass Net / Black Handle





**ORGANIZING STORAGE CABINET / SHELVES - p.39**

Lime Wood / Small Prism / Glass Net / Black Handle







# ORGANIZING STORAGE CABINET

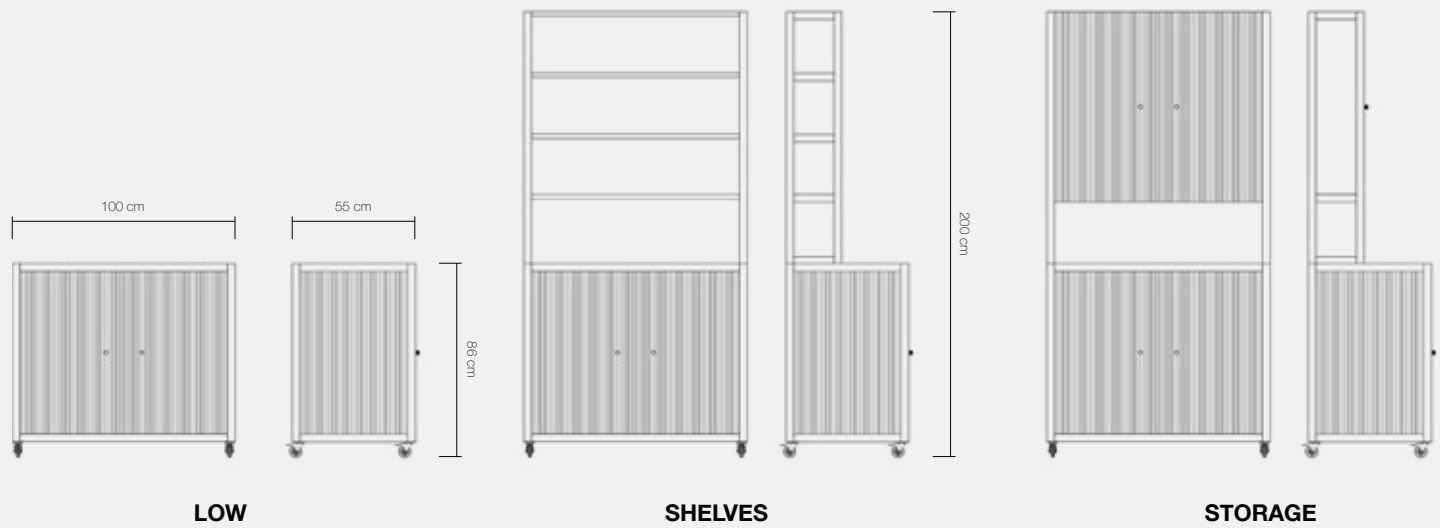

Versatile and functional, this item was created to house the products and allow the professional to prepare the pre-treatments on its top (e.g. colour mixing). It is available in three versions: the first, ideal for storage, only has the work surface and the concealed storage compartment; the second has shelves too, to place products and at the same time to create a precious display corner; the third achieves a top rationalisation of the spaces by providing a retractable compartment, in the upper area of the cabinet, with a hive-type structure ideal for storing the colours. The three types of furniture adapt to the environment's imprint, respecting its space and furnishing layout.

## / COLOURS /



## / TEXTURES AND COVERINGS /



## / WORK COUNTERS /

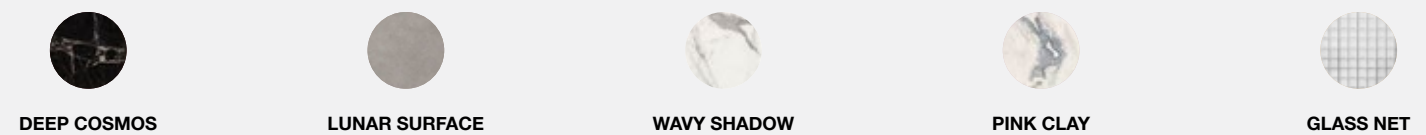

## / HANDLES /



# MIXING BACK WASH CABINET

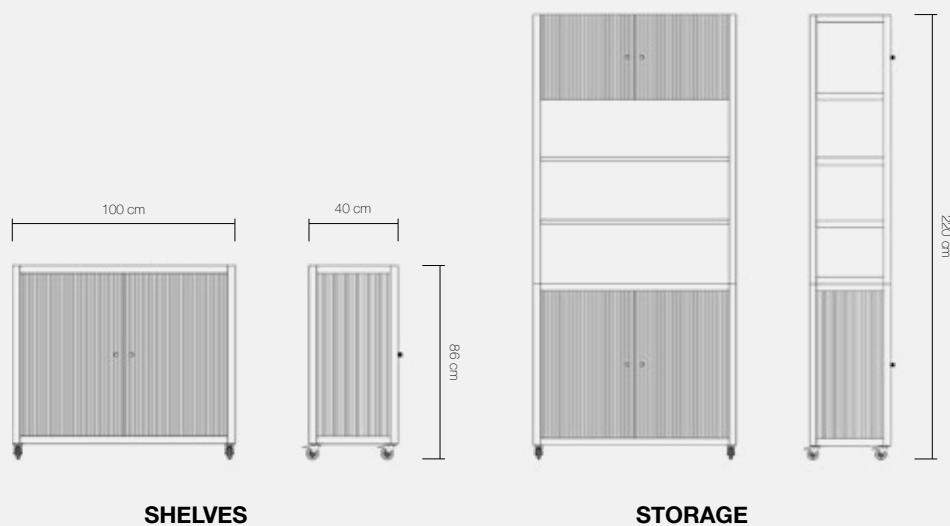

Identified by its positioning within the environment, this work unit is available in two versions: the first with doors only and the second complete with an upper structure, divided into several shelves. Both are shallower than the service cabinet and **the professional can easily manoeuvre them** in preparation for the cleansing and rinsing phase. **Designed to make treatments easier**, this unit is divided into support shelves, various compartments and a work surface. Space for storing towels is included.

## / COLOURS /



## / TEXTURES AND COVERINGS /



## / WORK COUNTERS /

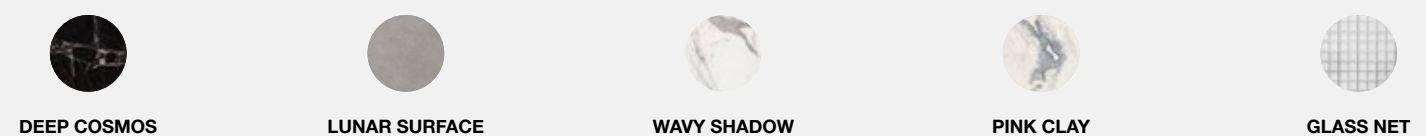

## / HANDLES /









# B L O O M I N G   D E S K

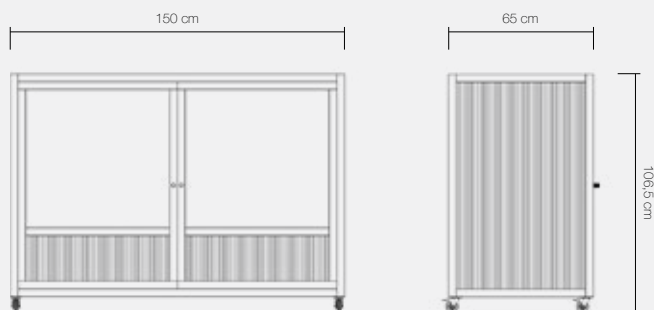

The reception desk, the welcome and service cabinet immediately visible to customers, is designed to promote **Agricosmetics in the salon's daily life**. Compared with traditional furnishings, this solution allows the professional to **recreate a green corner in the workplace**, promoting indoor gardening and plant care. On the front of the desk, protected by glass doors, **a small greenhouse and a purple grow light** create the right conditions for cultivation and embellish the salon's furnishings. This special indoor nursery is also completed by a **space for storing gardening tools**. The back, used for accounting and office activities, has shelves and drawers for storage.

## / COLOURS /



BLACK SUBSOIL



MINERAL GREY



WHITE FROST



MAJORCA PINK



LIME WOOD

## / TEXTURES AND COVERINGS /



ROUND



SMALL PRISM



PRISM



SMALL CORRUGATED



CORRUGATED

## / WORK COUNTERS /



DEEP COSMOS



LUNAR SURFACE



WAVY SHADOW



PINK CLAY



GLASS NET

## / HANDLES /



BLACK HANDLE



WHITE HANDLE



BLACK KNOB



GOLD KNOB



METAL KNOB



# CRAFTING TROLLEY

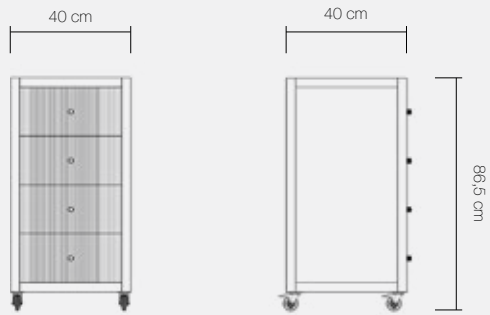

The portable technical trolley, essential for the professional's work, has drawers on the front to store the work tools required for the treatment. Towel hooks and brackets for placing bottles of product are positioned on its sides, **designed to optimise times, compress spaces and facilitate the treatment without having to move away from the workstation**. The glass and ceramic top, designed for preparations, **has a stain-resistant finish and can therefore be easily treated** with common cleaning products intended for these surfaces.

## / COLOURS /



BLACK SUBSOIL



MINERAL GREY



WHITE FROST



MAJORCA PINK



LIME WOOD

## / TEXTURES AND COVERINGS /



ROUND



SMALL PRISM



PRISM



SMALL CORRUGATED



CORRUGATED

## / WORK COUNTERS /



DEEP COSMOS



LUNAR SURFACE



WAVY SHADOW



PINK CLAY



GLASS NET

## / HANDLES /



BLACK HANDLE



WHITE HANDLE



BLACK KNOB



GOLD KNOB



METAL KNOB



# CRAFTING UNIT

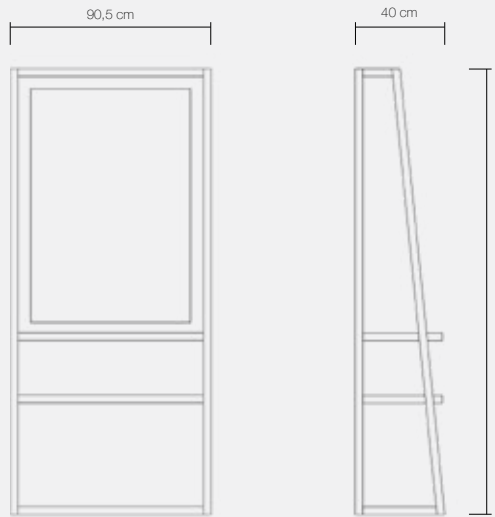

**Intended for the cutting and styling station**, the mirror is completed by two shelves, a support surface and a hairdryer holder, to place the drying tool when not in use. **The elegance of its line and the classic look ensure it adapts to any type of environment.** The presence of support shelves facilitates the use of hair dryers, brushes and straighteners for drying and defining and provides the mirror with various functions.

## / COLOURS /



**BLACK SUBSOIL**



**MINERAL GREY**



**WHITE FROST**



**MAJORCA PINK**



**LIME WOOD**

## / WORK COUNTERS /



**DEEP COSMOS**



**LUNAR SURFACE**



**WAVY SHADOW**



**PINK CLAY**



**GLASS NET**





# SEPARATING WINDOW

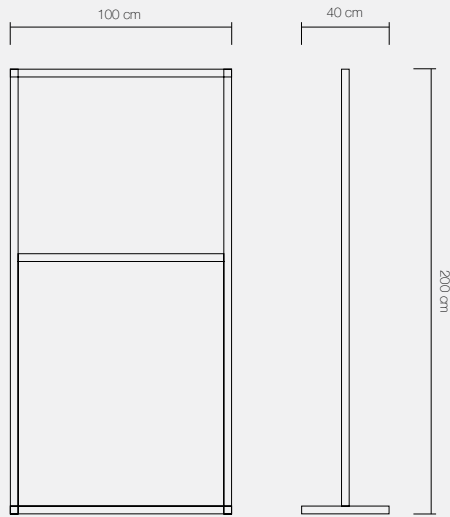

A protective glass and wood panel to define the area reserved for the colour, cut and styling station: elegant, modular and customisable with the salon's logo. Ideal for distancing customers in internal environments and for shielding them from the droplet effect without losing sight of the objective of sustainability, thanks to the choice of resistant, natural and non-impacting materials. **The partition wall is eco-designed to circumscribe the work area with a practical alternative solution to Plexiglas**, a commercial name commonly used to identify polymethylmethacrylate plastic. With an eye to the future and to the post-emergency, the choice of 100% recyclable glass and wood **has the advantage of allowing a sustainable disposal of the panel.**

## / COLOURS /



BLACK SUBSOIL



MINERAL GREY



WHITE FROST



MAJORCA PINK



LIME WOOD



# CHILLING WASH UNIT

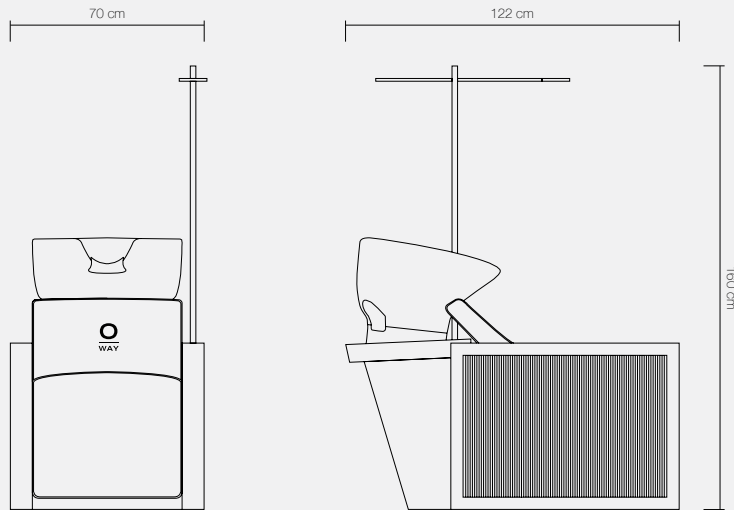

This piece of furniture is the result of the synergy between the strength of the zero-mile circular design of Artigiano and the experience in professional furnishings of Maletti. The body and seat signed by Maletti are inspired by the combination with the sides made in the Oway wood workshop, providing a unique identity in Oway's beauty environments. The wash unit chair is the result of a balanced mix of comfort, design refinement and exclusivity of the treatments, and is pre-set to house the pole for the Hydro-Dhara ritual, a holistic wellness experience in the salon. The ceramic cover provided for customising the armrests confirms Modulo's unique and differentiating quality, achieving two indispensable effects in one: to contrast the wear of the armrest, given by the rubbing of accessories or by the impact with sharp objects, and the perfect combination of the chair with the furnishing style chosen to characterise the salon. Compared with traditional wash units, the matte black basin identifies the Oway style and characterises the uniqueness and refinement of the product, branded on the back.

## / COLOURS /



BLACK SUBSOIL



MINERAL GREY



WHITE FROST



MAJORCA PINK



LIME WOOD

## / TEXTURES AND COVERINGS /



ROUND



SMALL PRISM



PRISM



SMALL CORRUGATED



CORRUGATED

## / WORK COUNTERS /



DEEP COSMOS



LUNAR SURFACE



WAVY SHADOW



PINK CLAY



GLASS NET





# DE-STRESSING ARMCHAIR

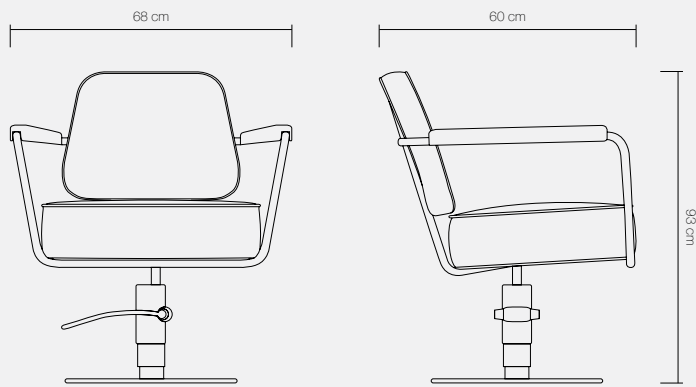

The seat designed by Maletti, personalised on the back with the Oway logo, has an adaptable height and customisable arm rests. As in the case of the wash unit, this is a piece of furniture with a refined and distinctive style, **capable of combining comfort with the quality** of the finishes and coverings. The style of Modulo and the touch of Artigiano are recognisable in its armrests, available in **100% tailor made** versions, and allow the salon to stand out and **give the environment a touch of uniqueness** and sustainable design.

## / ARMRESTS COLOURS /



**BLACK SUBSOIL**



**MINERAL GREY**



**WHITE FROST**



**MAJORCA PINK**



# G R O W I N G T E R R A C O T T A

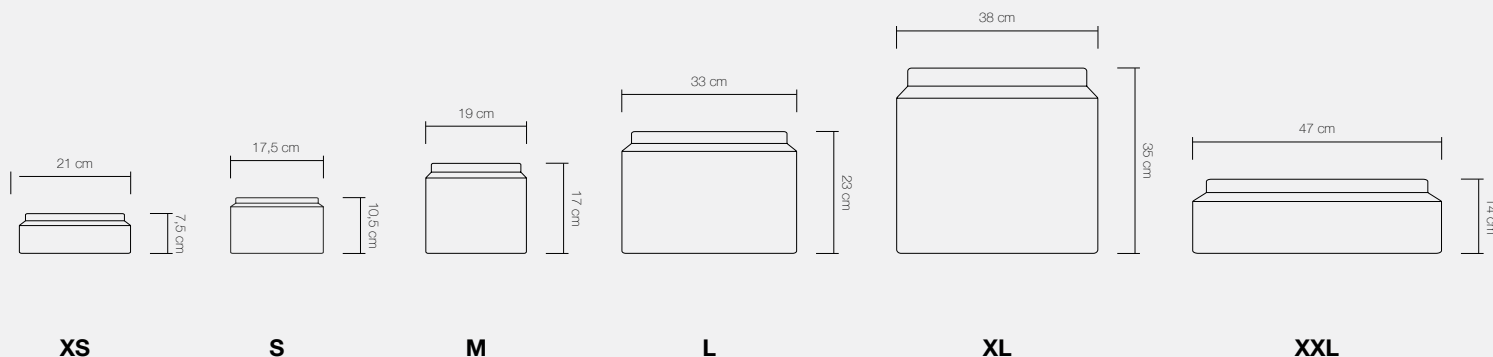

The Modulo project, in full Oway style, **focuses on attention to detail, both for the furniture and for the furnishing accessories.** To give the beauty salon an even more tactile, essential and ecological imprint, the Oway furniture line offers a precious **terracotta vase handcrafted in Faenza.** This object combines perfectly with all the furnishing accessories of the salon, from the mirror to the shelves to the service cabinets, and decorates the environment in a natural and refined way.



/ 100%  
HANDMADE IN  
FAENZA-ITALY /

**Ceramic** is one of the oldest art forms, deeply connected to nature.

The raw material, clay, is a natural product, a material which comes from the earth. In order to be able to give it the desired shape, master potters mix it with water and finally cook it to transform an idea into a durable and precious object.

Each piece of the Modulo offer of terracotta vases is a unique object, handmade individually by **expert craftsmen from our regional territory**, the cradle of the ceramic tradition and ambassadors of Italian craftsmanship.







# GLOWING TERRACOTTA

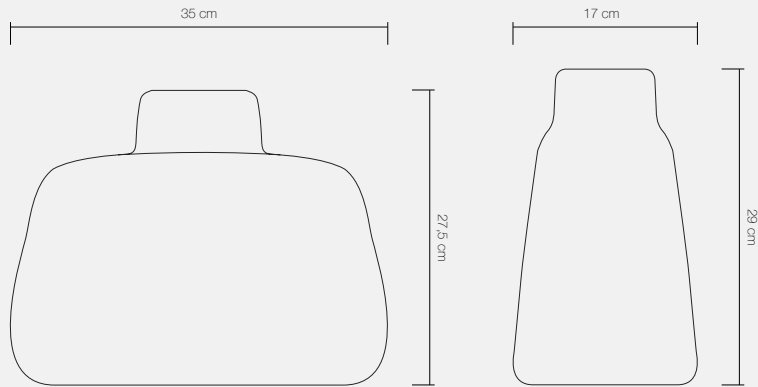

The design project of the lamps for the ceiling lighting of the salon was developed in the same Faenza workshop where the vases are created, consistently with their style and essentiality. **A suspended item made of ceramic**, shaped as a cylinder with an increasingly narrow diameter as it proceeds upwards, whose internal surface is in **glazed terracotta**. The lamp radiates natural and pleasant lighting, **in line with the ideal relaxing atmosphere in order to experience the Oway treatments**.

---



## / TERRACOTTA /

**Terracotta** originates from the processing of clay and is a **compound of minerals**, including magnesium, calcium, potassium, zinc, selenium, silicon, copper, iron.

Depending on the predominance of the minerals in its composition, **it can take on different colours**, ranging from white to yellow, red, grey, blue, beige and pink shades.

**The rough beauty of terracotta** combines with any type of residential and professional context, giving it a touch of originality and elegance.



# FLOATING SUPPORT

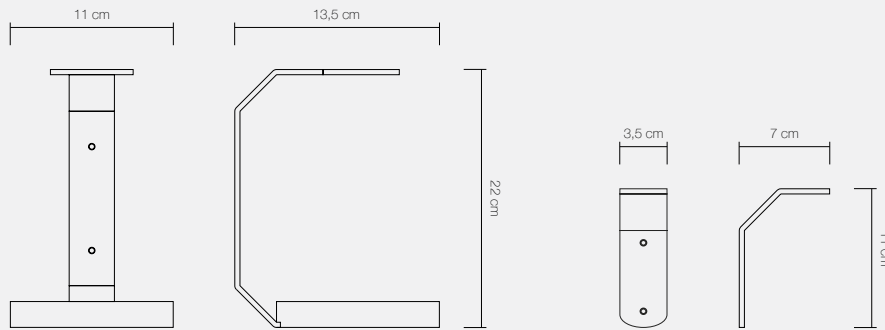

Customisation reaches every corner of the salon: from furniture to lighting, from furnishings to **the accessories which define the personality of an actual beauty temple**. Modulo has been designed to allow the utmost characterisation of the workspace and to assist the professional's movements: this is why the set-up **envisages anchoring drying products and tools to the furniture, by means of tailor-made brackets** produced according to the principles of circular design and effective sustainability: **functional accessories, preparatory for positioning testers**, to be made available to the customer within a **perspective of transparency, full usability and potential resale**.

## / COLOURS /



BLACK SUBSOIL



MINERAL GREY



WHITE FROST



MAJORCA PINK



